

Variety of Performances for many Media Twin Screw Pumps and Systems

Series W, V, U and T

For Oil & Gas, Industrial and Marine Applications.



B Bornemann
Pumps



Bornemann was established in 1853 and has been designing and constructing pumps and pump systems for over 75 years.

In 1934, Bornemann began designing and manufacturing our Twin Screw Pumps with external bearings, which today are still the foundation of our production and the premier pump in our product line.

Agencies and subsidiaries throughout the world guarantee immediate and professional support in all phases of business from extensive consulting through professional engineering to the installation and reliable maintenance of the installed pump and system.

Bornemann is certified under DIN EN ISO 9001.

1853 - 2003: 150 years tradition and innovation.

Multi-Purpose Pumping Solutions for a Variety of Fluids



Bornemann offers a wide range of twin screw pumps with external bearings with its "W", "V", "U" and "T" series. Optimised solutions are found for almost any application, including the fields of:

- Oil production
- Tank terminals, tank transfer
- Petrochemical industry
- Refineries
- Marine
- Offshore production

Application advantages:

- Wide range of applications
- Self-priming
- Pumped capacity proportional to speed
- Compact construction
- Direct drive without speed-reducer possible
- Change of pumping direction - simple
- Pumping elements - simple to replace
- Easy maintenance
- For almost all media and fluids
- High viscosities possible
- Low pulsations
- Low noise level
- Dry running possible
- Constant flow at varying pressures and volumes
- Very good suction performance up to NPSH 1-1.5 m / 3-5 feet
- Engineered 2-piece shaft and screw construction



Method of Operation

While pumping there is no metal-to-metal contact within the pump housing. This allows good pumping performance even with non-lubricating and corrosive and contaminated fluids. Even extended periods of dry-running are possible with the Bornemann Pump Design.

As the pump rotates, the intermeshing of the two screws along with the pump housing form chambers. These chambers fill with the pumped fluid and move it from the suction side of the pump to the higher pressure discharge side of the



pump. The pump is designed to allow for reverse flow by simply changing the shaft direction. The suction becomes the discharge and vice versa, all without any modifications to the pump.

FLUTROL
SOLUÇÃO EM ALTA PRESSÃO!

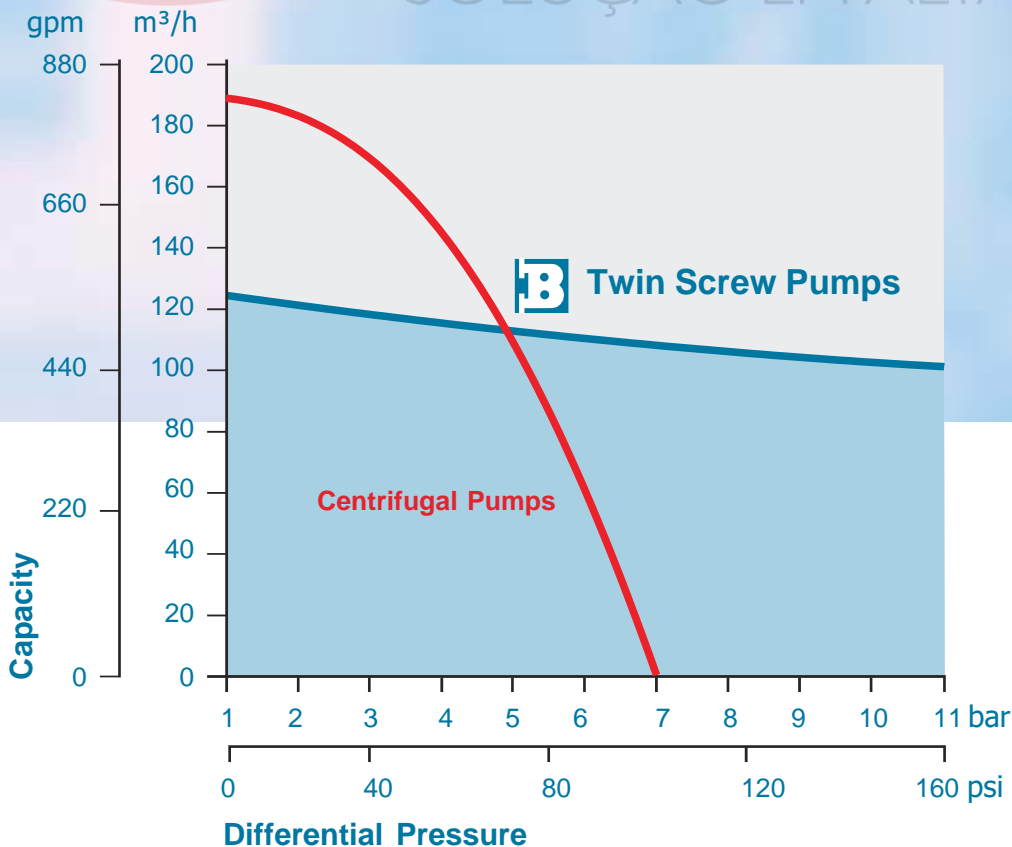



When selecting a pump with a small pitch angle, the back-flow or by-pass flow along the screw tips is extremely negligible. This results in very low NPSH requirements, and very good suction performance and low noise operation.

By varying the pitch of the screws the various pressures and flow rates can be achieved.

Bornemann pump engineered 2-piece screw and shaft design allows for easy change-out of screw pitches. This also allows for a pump design where the shaft and screws are made of different materials. This means the Bornemann Pump to be tailored to your specific pump application.

Bornemann pumps cover a wide range of pressures, flow rates, temperatures, and viscosities to accommodate almost any pumping media requirement. When compared to centrifugal pumps, Bornemann pumps can be applied for almost any fluid application low or high viscosity, non-lubricating, neutral or aggressive, clean or contaminated.



Pump Design

- External bearings with no contact to media for long-life even when pumping corrosive or contaminated media
- Large bearing housing with sufficient cooling without external cooling system
- Hardened and precision ground timing gears made of tempered steel
- Can transmit high torque at low noise levels
- Precision setting maintained even after dismantling, no adjusting necessary
- Oil level monitored with sight glass, no dismantling necessary
- Symmetrical housing for changing orientation of suction connection by a simple turn of the housing
- Symmetrical housing design so that flow direction can be easily changed





- Optimised mechanical seals to suit the specifics of each application
- Single mechanical seal (reversible) with optional subsequent lip seal for use with flushing fluid
- Double mechanical seal with flushing connection
- Replaceable screws
- Flexible at varying flow rates
- Reversible flow direction without need to change pump internal components
- Wide selection of materials available
- Shaft replacement is made easy because of the 2-piece shaft and screw design
- Built-in recirculation
- Protected against overpressure
- External safety not required
- Pump design protects against mechanical jamming due to air and steam penetration!
- Vapour locking does not occur because of constant presence of liquid
- Pump screws always immersed in pumped fluid because suction connections positioned above the center of the conveyor screw
- Cooling and lubrication ensured when used in stripping applications.
- Replaceable housing liner/inserts
- Replaceable liner reduces down-time and is possible without removing pump from piping

Series

Series W



Series W

Series W pumps are horizontal twin screw pumps with external bearings. In this design, the bearings do not come into contact with the media. The short model (W zk) is used for applications with high differential pressures.

The rotating faces of the mechanical seals are in the pumping flow (not dead-end). This ensures proper cooling and lubrication. The mechanical seals are on the suction side of the pump and therefore only see suction pressure, never the full higher discharge pressure. In the long model (W z), almost any seal design is possible.

A further advantage of this longer design is that it can pump fluids at higher temperatures up to 350 °C / 660 °F.

For the pumping of clean and lubricating media (e. g. lubricating oils), the pumps are available in zi-design, with internal bearings.

Series V

The pump principle is also available for vertical arrangement the so-called "inline design". In this model the suction and discharge connections are arranged in-line, horizontally. As a result of the symmetric design, the suction and discharge are interchangeable. This series is ideal for use in constricted areas. It is installed on a pump socket. The vertical motors are coupled directly to the pumps - without gears.

Series V



Pump Code

W 3. 2 zk 94

- Pitch in mm
- Bearing design
 - zk= centered short design
 - z= centered long design
 - zi= centered design with internal bearings
- Material index
- Sizes (3-10)
- Twin Screw Pumps
 - W= horizontal
 - V= vertical
 - U= immersed pump with internal bearings
 - T= submerged



Series T

Series U

This pump is selected where the pump needs to be installed inside the storage tank. The pump and its screws and bearings are immersed and lubricated by the pumped fluid. This series may only be used for clean lubricant oil. Immersions of up to 7 m / 23 ft are possible. Pressure connections and the drive motor are installed on the mounting flange of the tank.

Series T

Vertical submerged pump. The pump is installed directly within the tank or container where the fluid is stored. Hydraulic motors are normally used and directly connected to the pump. The pump and motor are installed and submerged in the tank and fluid.

external bearings		internal bearings				DIN / ASTM			
W.z(k)	V.z(k)	W.zi	V.zi	U.zi	T.zi	casing	liner	*shafts	screws
X	X	X	X	X		GG-25 / A48		1.4542 / A564	GG-25 / A48
X	X		X			GGG-40 / A536		1.4542 / A564	GG-25 / A48
X	X					GS-45 / A2765-35		1.4542 / A564	GG-25 / A48
X	X					GG-25 / A48		1.4542 / A564	1.4057 / A276
X	X					GG-25 / A48		1.4542 / A564	2.1090 / B144
X	X					GG-25 / A48		1.4542 / A564	1.4542 / A564
X	X					2.1052		1.4542 / A564	2.1090 / B144
X	X					2.1052		1.4542 / A564	1.4057 / A276
X	X					1.4408 / A351,A743		1.4542 / A564	1.4542 / A564
X	X					welded steel	GG-25 / A48	1.4542 / A564	GG-25 / A48
X	X					welded steel	Ni-Resist	1.4542 / A564	GG-25 / A48
X	X					welded steel	1.4408 / A351	1.4542 / A564	GG-25 / A48
X	X					welded steel	GG-25 / A48	1.4542 / A564	1.4057 / A276
X	X				X	welded steel	Ni-Resist	1.4542 / A564	2.1090 / B144
X	X					welded steel	1.4408 / A351	1.4542 / A564	1.4057 / A276
X	X					welded steel	1.4408 / A351	1.4542 / A564	2.1090 / B144
X	X					1.4571 / A182	1.4408 / A351	1.4542 / A564	1.4542 / A564
X	X					1.4462 / A789	1.4462 / A789	1.4542 / A564	1.4462 / A789

*shaft material zi= 1.7225 / A322

Series U

Performance

Capacity:	up to 2700 m ³ /h (12000 gpm)
Differential Pressure:	up to 50 bar (730 psi)
Viscosity:	0,5 up to 200000 mm ² /s (cSt)
Speed:	max. 3600 min ⁻¹ (rpm)
Temperature:	up to 300 °C (570 °F)

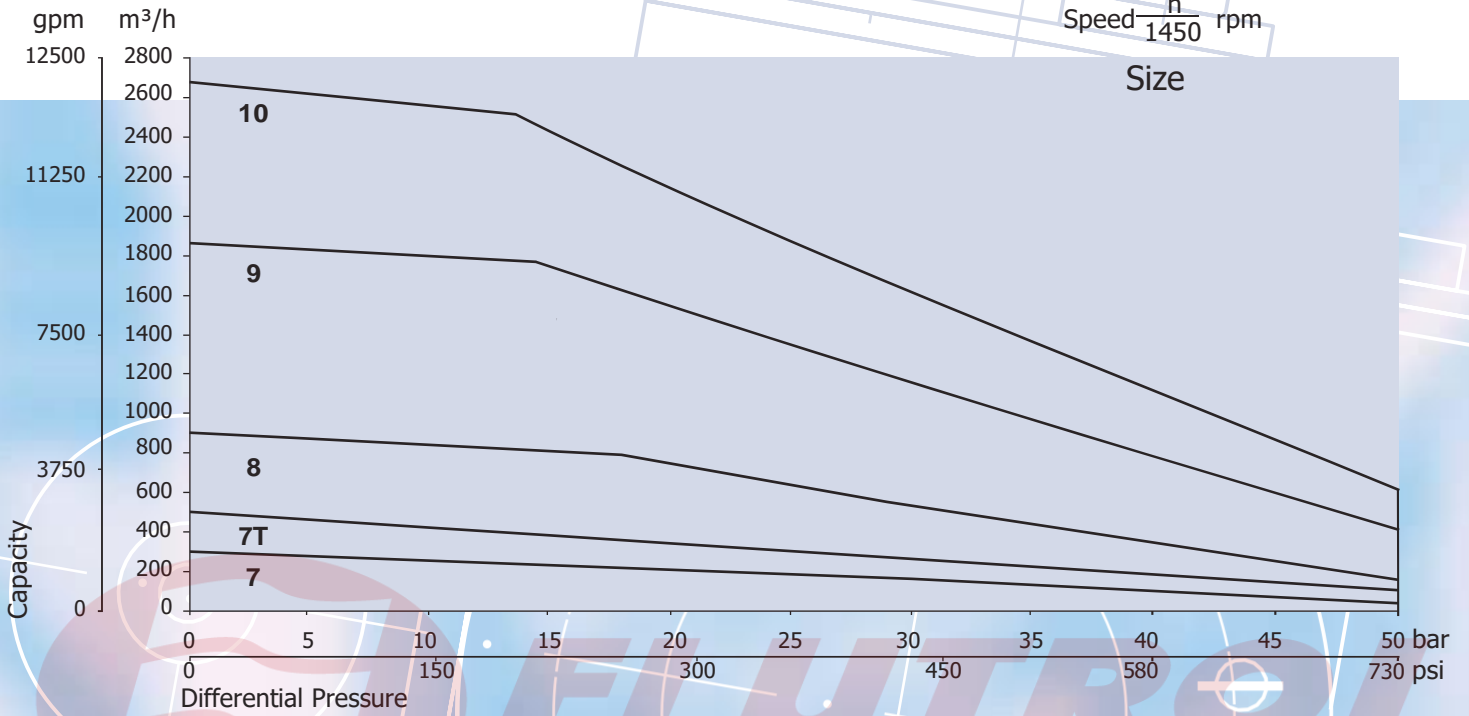

Capacity:	up to 150 m ³ /h (660 gpm)
Differential Pressure:	up to 35 bar (500 psi)
Viscosity:	0,5 up to 200000 mm ² /s (cSt)
Speed:	max. 3600 min ⁻¹ (rpm)
Temperature:	up to 300 °C (570 °F)

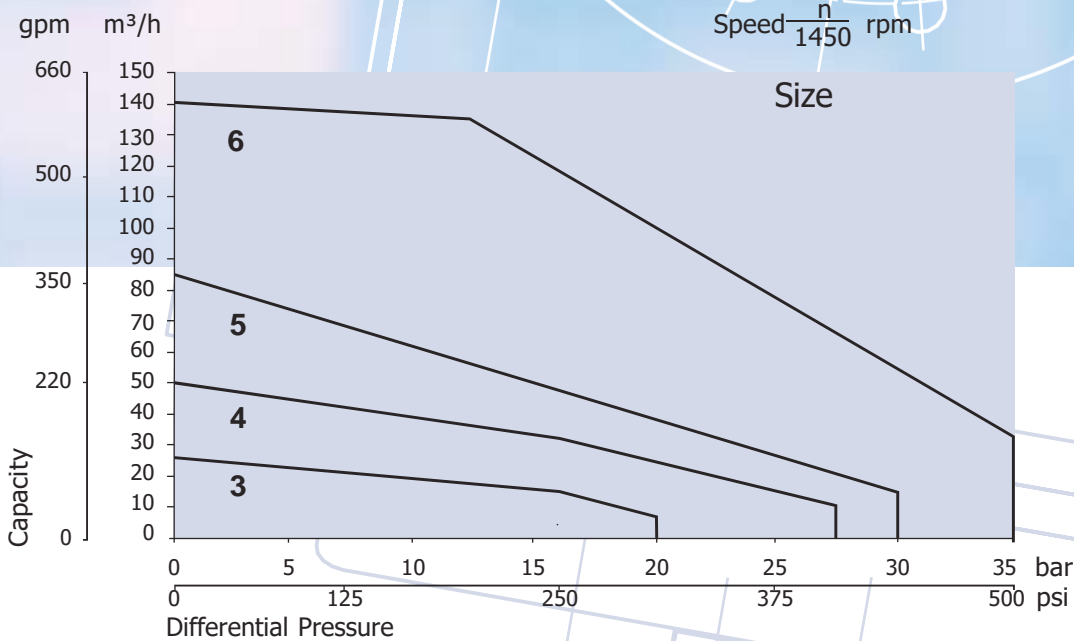

Pump Heating Options

To ensure proper heating of pumped fluids, Bornemann pumps can be constructed with the options below:

- Fully heating jacket or electrically traced heating with insulation available for the fabricated execution.

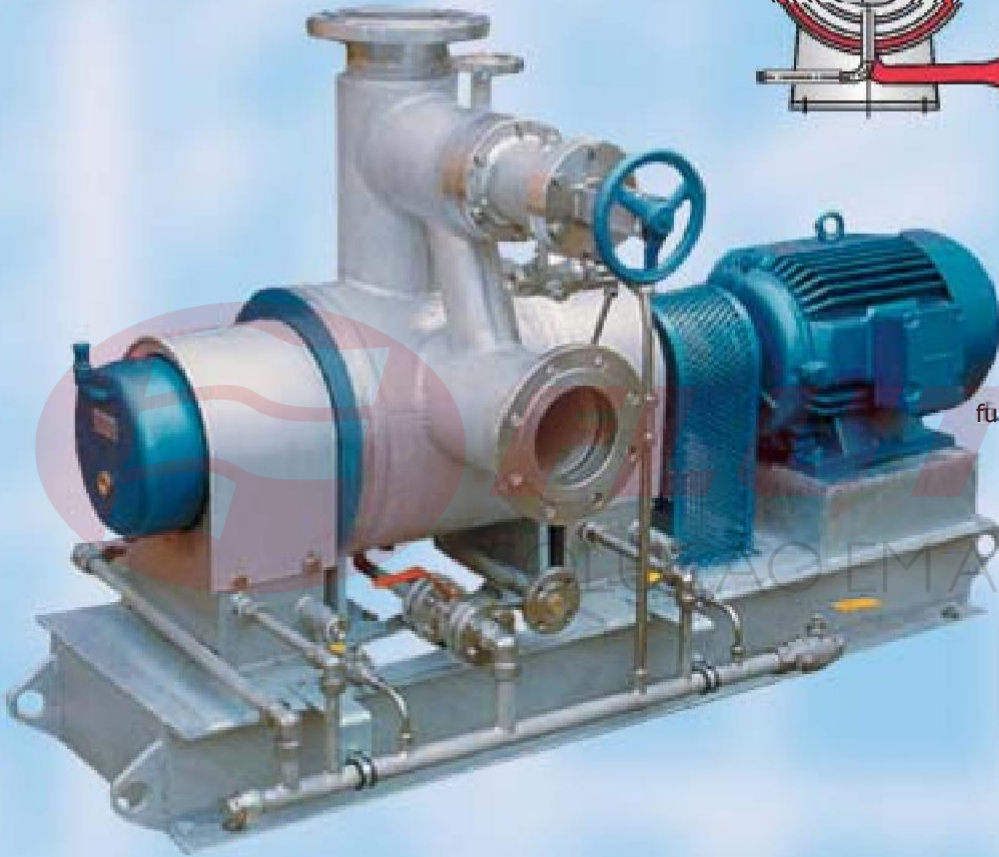
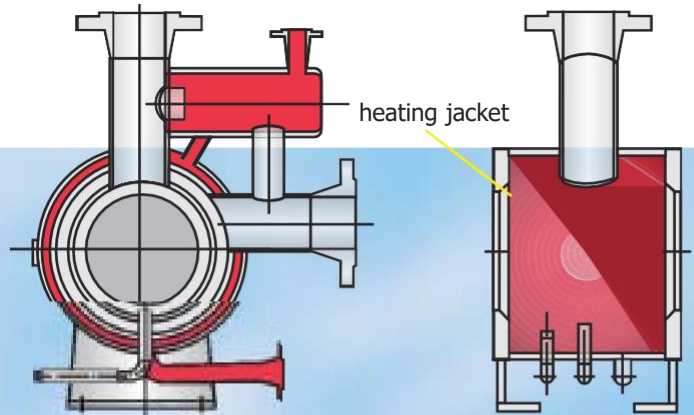

- Heating foot, coil for thermal oil / steam or electrical trace heating with insulation available for the cast execution.

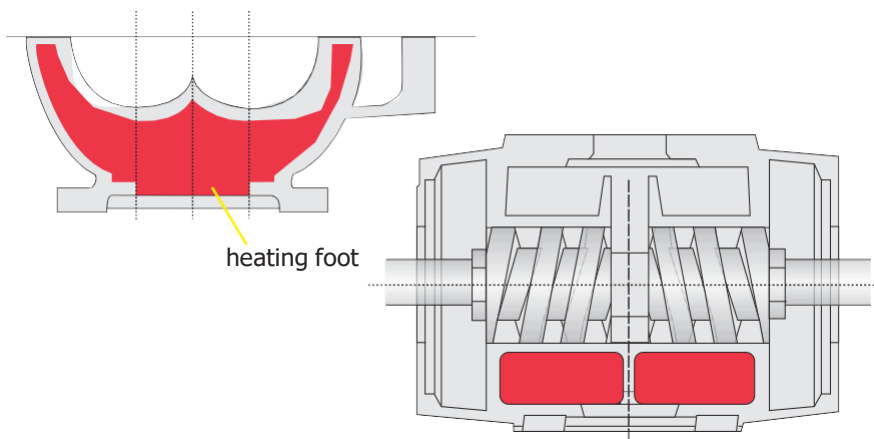

Sizes

Series W

		short long		short long							
		A	A	B	C	D	D	M	K	H	F
W3	casted	1100	1200	450	400	600	750	950	50	230	460
	welded	1050	1200	450	400	600	750	950	50	330	690
W4	casted	1340	1200	600	500	660	820	1150	60	310	570
	welded	1370	1200	600	500	690	820	1150	60	380	760
W5	casted	1440	1700	700	600	740	1000	1350	60	370	660
	welded	1440	1700	700	600	740	1000	1350	60	385	860
W6	casted	1780	1900	800	720	980	1100	1600	80	400	790
	welded	1780	1900	800	720	980	1100	1600	80	495	995
W7	casted	2000	2200	920	760	1080	1280	1900	80	470	900
	welded	2000	2200	920	760	1080	1280	1900	80	585	1135
W7T	casted	2400	2800	1200	1000	1200	1600	2300	240	550	1120
	welded	2600	2800	1200	1000	1400	1600	2300	240	750	1500
W8	casted	2900	3300	1400	1200	1500	1700	3300	280	740	1400
	welded	2900	3300	1400	1200	1500	1700	3300	280	1000	1800
W9	casted	4000	—	2200	1600	1800	—	4300	280	980	1700
	welded	4000	—	2200	1600	1800	—	4300	280	1300	2200
W10	welded	—	5800	3400	1900	—	2400	6000	410	1300	2600

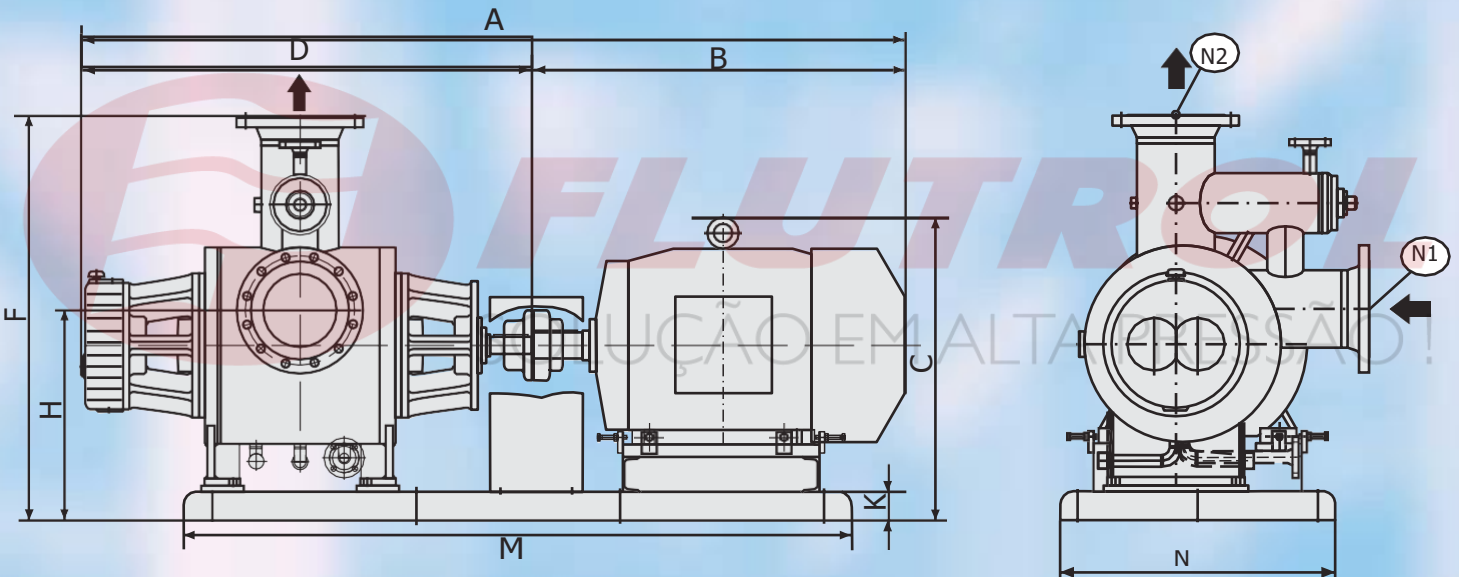

		short long		DIN		ANSI	Pump in kg		Total in kg	
		N	N	N1	N2	N1,N2	short	long	short	long
W3	casted	470	550	DN50, PN10	DN50, PN16	2" 150#	100	120	220	250
	welded	470	550	DN50, PN10	DN50, PN25/40		165	375	285	505
W4	casted	550	570	DN80, PN10	DN80, PN16	3" 150#	130	160	390	440
	welded	550	570	DN80, PN10	DN80, PN25/40		195	210	460	490
W5	casted	570	660	DN100, PN10	DN100, PN16	4" 150#	220	260	500	540
	welded	570	660	DN100, PN10	DN100, PN25/40		285	305	590	585
W6	casted	660	720	DN150, PN10	DN150, PN16	6" 150#	380	420	830	870
	welded	660	720	DN150, PN10	DN150, PN25/40		395	400	865	850
W7	casted	720	780	DN200, PN10	DN200, PN16	8" 150#	590	620	1170	1200
	welded	720	780	DN200, PN10	DN200, PN25		740	950	1320	1530
W7T	casted	820	880	DN250, PN10	DN250, PN16	10" 150#	1170	1320	2770	2860
	welded	1150	1135	DN250, PN10	DN250, PN25		1350	1530	3150	3300
W8	casted	1290	1450	DN300, PN10	DN300, PN16	12" 150#	1560	1640	5200	5400
	welded	1600	1700	DN300, PN10	DN300, PN25		2000	2100	6000	6200
W9	casted	1400	—	DN400, PN10	DN400, PN16	16" 150#	2600	—	8950	—
	welded	1700	1800	DN400, PN10	DN400, PN25		4000	4210	10350	10770
W10	welded	—	2200	DN500, PN10	DN500, PN25	20" 150#	—	5800	—	18000

Series V

		A	B	H	E	F	G
V6	casted	2000	720	700	500	440	340
	welded			550			
V7	casted	2300	870	740	500	540	390
	welded			740			
V7T	casted	2900	1170	860	600	700	430
	welded			860			
V8	casted	3900	2060	1100	700	700	440
	welded			1100			
V9	welded	4600	2390	1300	900	750	560
V10	welded	5100	2520	1500	1000	810	770

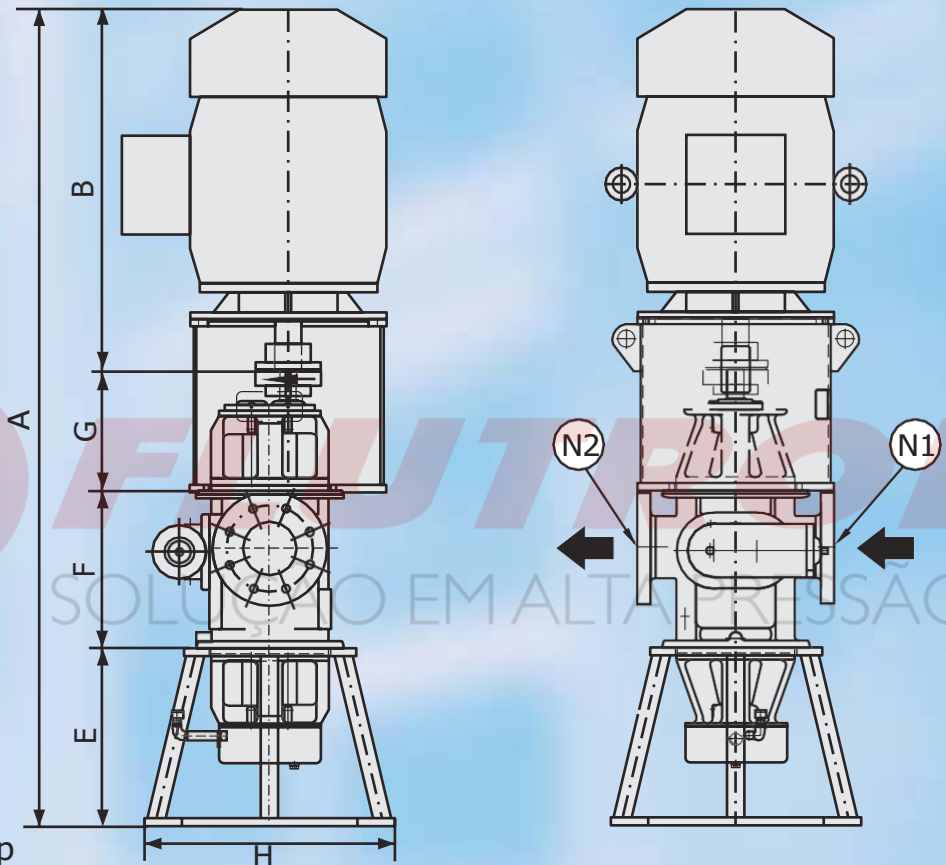

Depending on the pump type, pump sockets are installed up to a certain size of the motor. Pump pedestals are used with larger motor sizes.

Dimensions shall not be used for constructive purposes.

		DIN		ANSI	Pump	Motor	Total
		N1	N2	N1, N2	kg	kg	kg
V6	casted	DN200, PN10-16	DN200, PN16	6" 150 lbs	505	330	935
	welded	DN150, (*)	DN150, (*)	6" (*)	630		960
V7	casted	DN200, PN10	DN200, PN16	8" 150 lbs	820	430	1250
	welded	DN200, (*)	DN200, (*)	8" (*)	1400		1830
V7T	casted	DN250, PN10	DN250, PN16	10" 150 lbs	1275	830	2105
	welded	DN250, (*)	DN250, (*)	10" (*)	2220		3050
V8	casted	DN300, PN10	DN300, PN16	12" 150 lbs	2260	2200	4460
	welded	DN300, (*)	DN300, (*)	12" (*)	3360		5560
V9	welded	DN400, (*)	DN400, (*)	16" (*)	4160	3100	7260
V10	welded	DN500, (*)	DN500, (*)	20" (*)	4560	3900	8460

Dimensioned drawings for series U and T on request.

(*) Rating to be defined.

Reliable Performance, Day after Day, throughout the World.

Bornemann twin screw pumps prove their worth in pumping applications of all kinds throughout the world, which must perform under extreme environmental conditions. Their advantages are operational safety, reliability, and consistent performance, long life and low operating costs.

Oil Production

Bornemann twin screw pumps as transfer pumps are excellently suited to pump mixtures of crude oil, gas, waste and fine particles. They can be used both on and offshore. The ability for the pump to run dry safely allows for the inclusion of gas in the pumped streams. The short bearing design and small screw pitch make it possible to generate high pressures for pipeline applications.

Product applications: crude oil containing gas and water, very heavy crude oil ...

Tank Terminals

Bornemann has a large worldwide installed base of pumps in tank terminals. They can be used wherever a large suction capacity is required. Bornemann Pumps can be found for loading and unloading of ships, tank wagons, tanker trucks as well as storage tanks and pipelines everyday of the year. They perform these duties under challenging conditions including high viscosities and pressures.

Product applications: low to very high-viscosity oil products such as bitumen, tar, chemicals, light and heavy fuel oil, crude oil, mazut ...

Petrochemical Industry / Refineries

Bornemann twin screw pumps are the ideal solution for transfer within terminals where both low and high viscosity products have to be moved or metered. All fluids whether neutral, alkaline or acid and aggressive, abrasive or gaseous are sucked up safely, dosed and pumped.

Product applications: mazut, bitumen, tar, heavy fuel.

Marine and Shipbuilding, Offshore.

Bornemann pumps are excellently suited as loading and unloading pumps. Their proven advantage is the easy transfer of fluids with various viscosities such as heating oil, and storage water.

Chemical Industry

Bornemann pumps offer convincing advantages where chemicals are concerned. Because there is no contact between the moving parts in the fluid stream, it is possible to make fluid contacting parts from stainless steel. The result: non-lubricating, corrosive, low viscosity and high viscosity fluids can be conveyed. Bornemann pumps are particularly well suited for shear sensitive, viscous fluids that have to be pumped and handled with care.

Product applications: polymers, liquids sulphur ...



Tank Terminal

Country: U.A.E.
Pump type: W9
Medium: Fuel oil, 55 °C / 130 °F, 380 cSt
Capacity: 120 - 1400 m³/h / 530 - 6200 gpm
Pressure: 10 bar / 145 psi
Speed: 200 - 1470 rpm
Shaft power: 75 - 500 kW / 95 - 630 HP



Refinery

Country: Germany
Pump type: W7T
Medium: Molasses, 220 - 250 °C / 430 - 480 °F, 350 cSt
Capacity: 110 - 240 - 370 m³/h / 480 - 1060 - 1600 gpm
Pressure: 11 bar / 160 psi
Speed: 600 - 1200 - 1800 rpm
Shaft power: 150 kW / 190 HP



Offshore

Country: Norway
Pump type: W6
Medium: Produced water, 2 - 70 °C / 35 - 160 °F, 0,4 - 1,7 cSt
Capacity: 21 m³/h / 95 gpm
Pressure: 3 bar / 45 psi
Speed: 1400 rpm
Shaft power: 5 kW / 7 HP



Marine

Country: China
Medium: Crude oil, 85 °C / 185 °F, 130 cSt
Capacity: 210 m³/h / 950 gpm
Pressure: 8 bar / 120 psi
Speed: 1450 rpm
Shaft power: 50 kW / 70 HP



Oil Production

Country: Oman
Pump type: W9
Medium: Crude oil, 25 - 45 °C / 80 - 120 °F, 900 - 4000 cSt
Capacity: 354 m³/h / 1600 gpm
Pressure: 12 - 15 bar / 180 - 220 psi
Speed: frequency converter
Shaft power: 300 kW / 410 HP



Chemical Industry

Country: Germany
Pump type: W7
Medium: Water, solvent, silicon acrylate, polyether,
20 - 130 °C / 70 - 270 °F, 1 - 15000 cSt
Capacity: 4 - 100 m³/h / 18 - 440 gpm
Pressure: 14 - 73 psi
Speed: 300 - 1400 rpm
Shaft power: 55 kW / 74 HP



Pumps and Systems for Industry,
Environmental and Shipbuilding

www.bornemann.com

Joh. Heinr. Bornemann GmbH

Postfach 1162

31676 Obernkirchen

Germany

Fon +49 5724 390-0

Fax +49 5724 390290

info@bornemann.com



FLUTROL

Good communication with our customers is an important feature in Bornemann's Quality Program, from initial project consultation to maintenance. Professional support and fast service are top priorities. Specialists in pumps and systems located in our company headquarters and in nearly 100 representatives

and agencies through the world provide professional quality support on a local level. Our employees and representatives are trained at our training center in order to stay current on new technologies and provide the best support available to our customers.



*São Paulo SP: Av. Santo Albano, 170 - CEP 04296-000
Tel.: (11) 6940.9053 - Fax: (11) 6940.9050*

*Rio RJ: Rua Tanagra, 27 - CEP 21031-560
Tel.: (21) 2560.7688 - Fax: (21) 2560.0451*

*Macaé RJ: Av. Rui Barbosa, 2069 A3 - CEP 27915-010
Tel: (22) 2770.4492 - Fax: (22) 2762.6009*